



QUOTATION DOCUMENTATION

Q45/18

***Carpark & retaining wall
(adjacent to Central Stores)***

***Quotations close at 11:00am on
Friday, 30 November 2018***

1. Introduction

Council is seeking quotations from qualified contractors for the construction of a block work retaining wall beside Central Stores off the main street of Gilgandra and form up the sub base of the proposed car parking area. This will allow for two vehicle parking bays and pedestrian access to the walking/cycle way at the rear of the CBD.



Figure 1 Site Location - Miller St next to Central Stores, Gilgandra

2. Scope

Retaining Wall

This project requires the supply and installation of a block retaining wall to form a parking area beside Central Stores, in accordance with the following specifications and design. The retaining wall will be a terraced walls not exceeding 1m vertical fall.

They are to meet or exceed the Australian Standards, meet Industry Best Practice, and as a minimum shall be in accordance with the following standards/guidelines:

- AS/NZS 4455.3:2008 Masonry units, pavers, flags and segmental retaining wall units
- AS 3798-2007 Guidelines on earthworks for commercial or residential developments
- AS/NZS 2566.2:2002 Buried flexible pipelines installation
- AS/NZS 3500.3:2015 Plumbing and Drainage
- AS 1289.0-2000 Method of testing soils for engineering purposes

Contractor is to follow the design illustrated in drawing CBDCP001. The cross-sections at each nominated chainage is noted on drawings CBDCP002, CBDCP003, CBDCP004 and CBDCP005 attached.

If the design is not clearly understood, please ask your contact at Gilgandra Shire Council (GSC) for clarification.

Contractor will also need to refer to the Austral Masonry Heron installation guide as per link <https://australmasonry.com.au/nsw/product/heron/#installguide>

Material Selection

The contractor will supply materials below:

- Austral Masonry Heron standard block, block capping, corner block and end block quantity to suit
- 100mm aggregate pipe
- Geofabric lining
- 25MPa concrete footing
- 411 Rectangular trench mesh
- 12-20mm free draining granular material (fill all cores of blocks)

Earthworks

Contractor to strip the topsoil to remove all grass, root growth, and wet and spongy natural soil to provide a solid base for the works.

Stripped topsoil is to be stockpiled in a clear area directed by GSC.

Place 100mm of compacted road base, and conform to the lines and grades as directed by GSC.

Grade of finished surface to allow for all water in the carpark to fall into existing drain (in consultation with GSC staff). The existing drain is to finish 10mm higher than the surrounding surface.

Once the desired finished surface is achieved, Contractor must perform compaction testing and achieve 98% compaction level and provide documentation as proof.

Before filling commences the Contractor shall make available for inspection the foundation of the embankment. GSC may order the removal of any soft spots, debris, or any other unsuitable material exposed when the topsoil has been stripped.

There will be a 10% retention of total payment from the point of practical completion for a period of 3 months to ensure correct drainage and construction stability.

3. Timeframe for Construction

The preferred timeframe for construction of the retaining wall and earthworks are to commence after the 14 January 2018 and be completed in January/February 2018.

4. Contact

Refer all enquires in relation to this quotation to:

Mr Chris Nguyen
Graduate Engineer
Gilgandra Shire Council
PO Box 23
Gilgandra NSW 2827
E-mail: cnguyen@gilgandra.nsw.gov.au
Phone: (02) 6817 8800

5. Submission of Quotations

Quotations shall be submitted on the attached compulsory Quotation form prior to 11am on Friday, 30 November 2018. Late quotations will not be accepted.

6. Assessment Criteria

- Price
- Conformance with quotation documentation
- Timeframe for construction

7. Work Health & Safety Regulations

The successful contractor may be required to participate in site induction and risk assessment and any safe work method statements necessary to complete the role.

Contractors are obligated to abide by Council's WH&S policies including, UV policy, drug and alcohol and personal protective equipment (copies can be obtained at Council's office) and to observe directions on health and safety from designated officers of the organisation. Failure to comply with this will be considered a breach of the agreement and sufficient grounds for termination.

The successful contractor will be required to provide a copy of all relevant licences. General monitoring will occur during the course of the contract.

8. Registration and Insurance

The successful contractor/s will be required to be registered on Statewide – Contractor Insurance Management System (CIMS). Statewide will verify your insurances, being:

- Public Liability Insurance policy of a minimum \$20,000,000
- Workers' Compensation Insurance or, for a sole trader or operative partner of partnership, evidence of a Personal Accident Insurance policy

All registration and insurance documents to be supplied to the CIMS portal prior to contractor commencing work.

9. Other Conditions

- a) Council is not bound to accept the lowest or any quotation, nor are they responsible for, or pay for expenses or losses which may be incurred by any consultant in the preparation of this quotation.
- b) By submitting a quotation, the contractor recognises and agrees to the terms and conditions outlined in this document.
- c) The contractor shall be satisfied as to the correctness of their quotation and sufficiency of the quotation for the works, and that the price covers the cost of complying with all obligations under this quotation documentation and all matters and things necessary for the due and proper performance and completion of the project.
- d) Notice of acceptance of a quotation shall be given in writing.

GILGANDRA SHIRE COUNCIL

STATEMENT OF BUSINESS ETHICS

GENERAL PRINCIPLES

Gilgandra Shire Council expects all its representatives, staff and Councillors to behave ethically and to abide by a written Code of Conduct. Council also expects private industry and its representatives to maintain similar standards of ethical conduct in their dealings with Council.

There are two main principles that form the basis of Gilgandra Shire Council's business agreements. Firstly, there is the need to get the best possible value for public money. Secondly, Council needs to demonstrate impartiality and fairness at all stages of the process.

These principles enable suppliers to promote their interests productively and avoid potentially questionable activity. Those providing goods and services also benefit from the assurance that their competitors are required to behave in accordance with the same guidelines.

VALUE FOR MONEY is determined by considering all the factors which are relevant to a particular process. For example quality, reliability, timeliness, service, initial and ongoing costs are all factors which can make a significant impact on benefits and costs. Value for money does not mean "lowest price".

However, the lowest price bid might offer best value if it meets other essentials such as quality and reliability.

IMPARTIALITY AND FAIRNESS are about being objective, even-handed and reasonable. An impartial person will try objectively to establish criteria for determining best value for money and will work hard to objectively assess each quotation against criteria. A fair person would not for example change or introduce new selection criteria midway through the quotation process without advising all persons submitting a quotation.

Being impartial includes taking into account the practicalities of a given situation. Impartiality does not require for example inviting bids from firms which have performed poorly in the past. In some circumstances, fairness takes into account the effects of actions of others. It would be unfair to call quotes when there is no serious intent to award a contract subject to a satisfactory offer.

Fairness does not necessarily mean pleasing everyone. Some people are occasionally adversely affected by fair decisions. Council operates from a view point where it wishes to be fair in all its dealings and minimise where possible, any adverse effects of its decisions.

Gilgandra Shire Council expects staff and Councillors to:

- Respect and follow Council's policies and procedures.
- Treat all quotes for the supply of goods and services equitably.
- Promote fair and open competition while seeking best value for money.
- Protect confidential information.
- Meet or exceed public interest and accountability standards.
- Respond promptly to reasonable requests for advice and information.
- Avoid situations where private interest could conflict with public duty.
- Never solicit or accept remuneration, gifts or other benefits from a supplier for the discharge of official duties.

Council expects tenderers, suppliers, consultants and contractors to:

- Respect the conditions set out in documents supplied by Council,
- Respect the obligation of Council staff to abide by Council's procurement and disposal policy.
- Abstain from collusive practices.
- Prevent unauthorised release of privileged information, including confidential Council information.
- Refrain from offering Council employees or Councillors any financial or other inducement which may give any impression of unfair advantage.

HOW IT WORKS

There is no absolute definition of "ethical behaviour". If there is any doubt about the ethics of a proposed action, a sensible test is whether or not you would be happy to see your behaviour published in the local newspaper.

Staff and Councillors of Gilgandra Shire Council or those in the employ of a tenderer, supplier, consultant or contractor who are concerned that a breach of the law or of ethical conduct may have taken place, should discuss the matter with Gilgandra Shire Council's Public Officer on (02) 6817 8800.

If an apparent breach of any agreed standard of ethical conduct is identified, then the matter should be immediately brought to the attention of the General Manager or the Public Officer on (02) 6817 8800.

CODE OF CONDUCT

Council contractors will also be required to observe the relevant provisions of Council's Code of Conduct based on the Department of Local government Model Code of Conduct for Local Councils in NSW, adopted by Gilgandra Shire Council March 2013.

The Code of Conduct is accessible on Council's website: www.gilgandra.nsw.gov.au.



QUOTATION 45/18
Carpark & Retaining Wall
(Adjacent to Central Stores)

CLOSING TIME – 11AM FRIDAY, 30 NOVEMBER 2018

I/we wish to submit a GST EXCLUSIVE quotation for the Carpark and retaining wall (adjacent to Central Stores, Gilgandra)	\$
I/we could have the scope of works completed during January/February 2018	YES / NO
If you answered NO, please provide an alternative timeframe for construction of the concrete works	

Referees:

No	Client	Contact Number	Details of Work	Value of Works
1.				
2.				
3.				

Please Note:

- Council has a local purchasing policy
- I/we confirm that I/we have read and are aware of Gilgandra Shire Council's Statement of Business Ethics
- I/we confirm that I/we have noted Council's requirements and confirm that I/we have not colluded with other persons submitting quotations in preparing this proposal

(Please print)

Company:	
-----------------	--

Company:			
ABN:			
Name of contact person:			
Address:			
Phone No:			
Email:			
Signed:		Date:	

Please submit this form in an envelope, clearly marked **Q 45/18**:

Via post to:

Gilgandra Shire Council
 PO Box 23
 Gilgandra NSW 2827

OR

Via fax to: (02) 6847 2521

Place in the Tender Box at:

Gilgandra Shire Council
 15 Warren Road
 Gilgandra NSW 2827

Via email to: council@gilgandra.nsw.gov.au

CHAINAGE 0.000

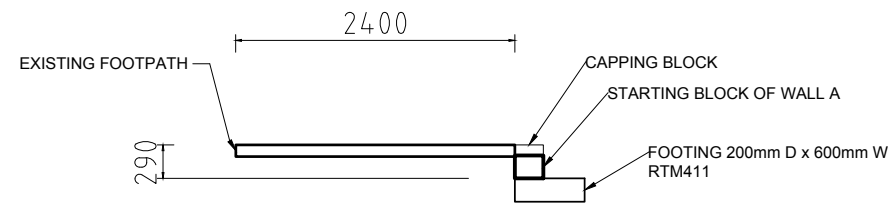

CHAINAGE 2.200

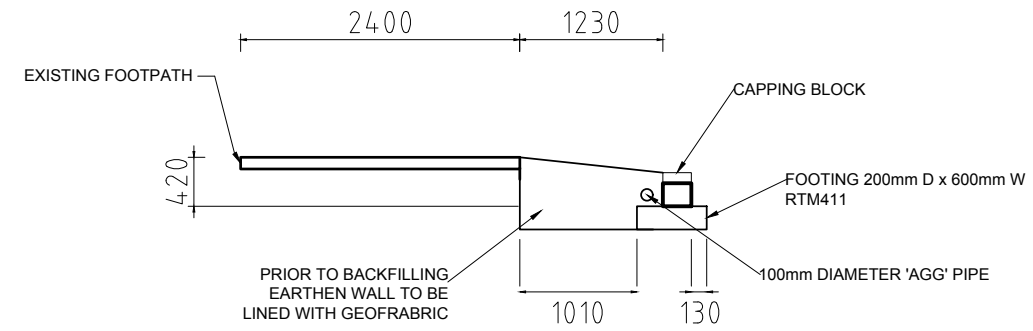

CHAINAGE 4.300

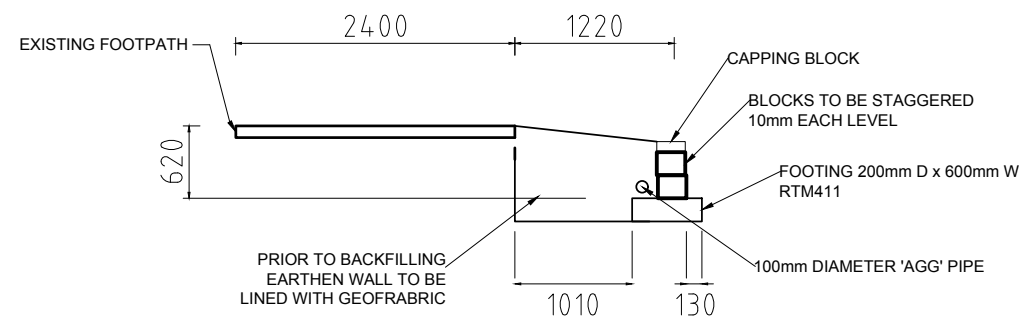

CHAINAGE 6.500

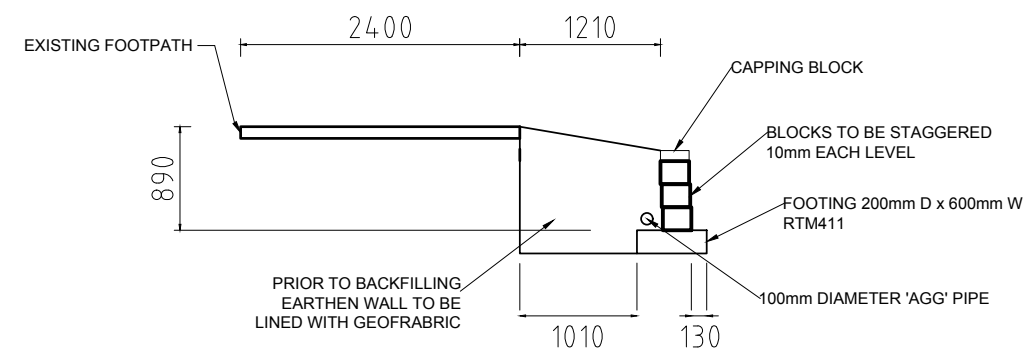

CBD-UPGRADE-STAGE2 CENTRAL-STORES-CARPARK CROSS-SECTIONS

TITLE CROSS-SECTIONS-SHEET1

CREATION DATE
5NOV18

DRAFTER
CN

PLOTTED DATE
5NOV18

SCALE
1:65

APPROVAL FOR ISSUE

ENGINEERING MANAGER

MANAGER

DRAWN TO AS1100 BY CAD
DO NOT AMEND MANUALLY
FIGURED DIMENSIONS TO BE
TAKEN IN PREFERENCE TO
SCALE READINGS.
VERIFY ALL DIMENSIONS ON SITE

SHEET
SIZE
A3

DRAWING No.

CBD-CP002

REVISION

1

CHAINAGE 8.600

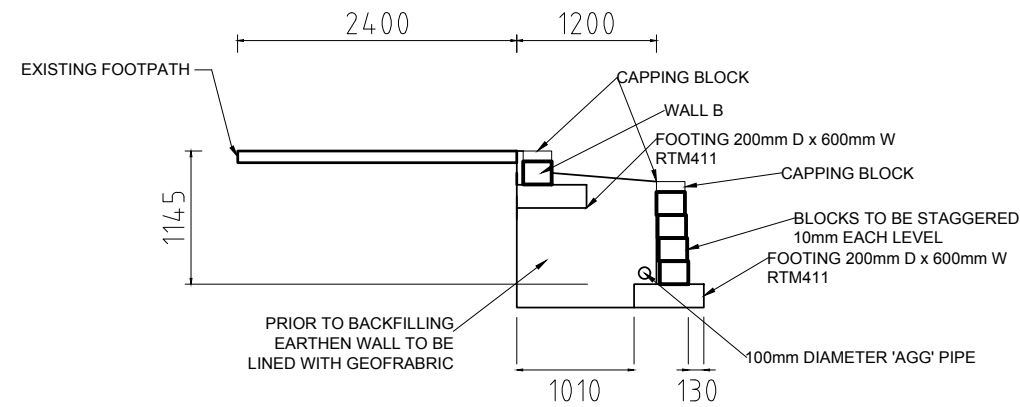

CHAINAGE 10.700

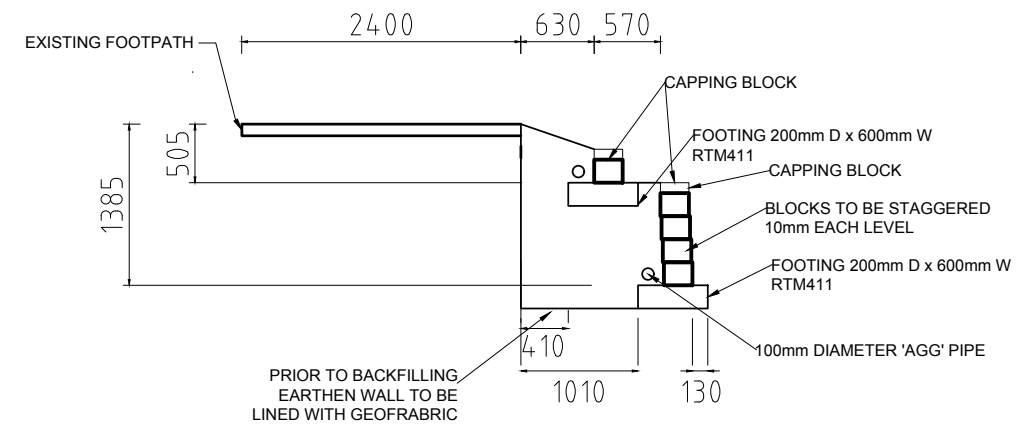

CHAINAGE 12.900

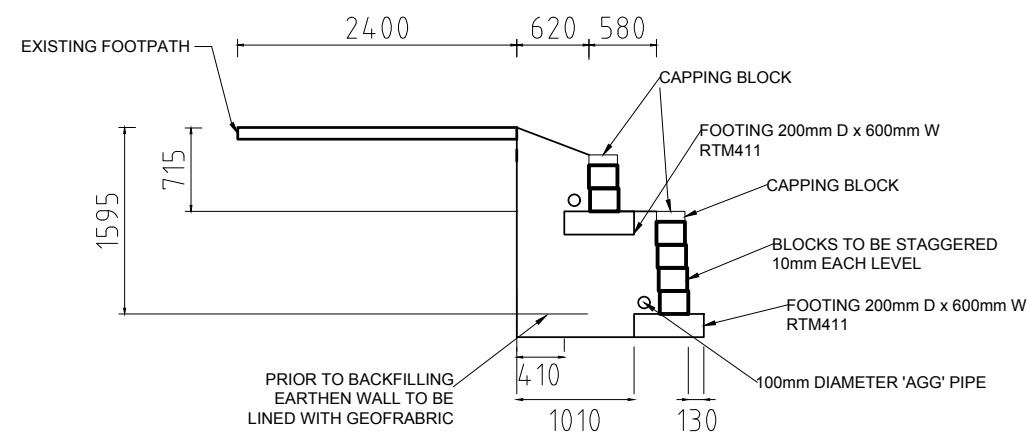

CHAINAGE 15.100

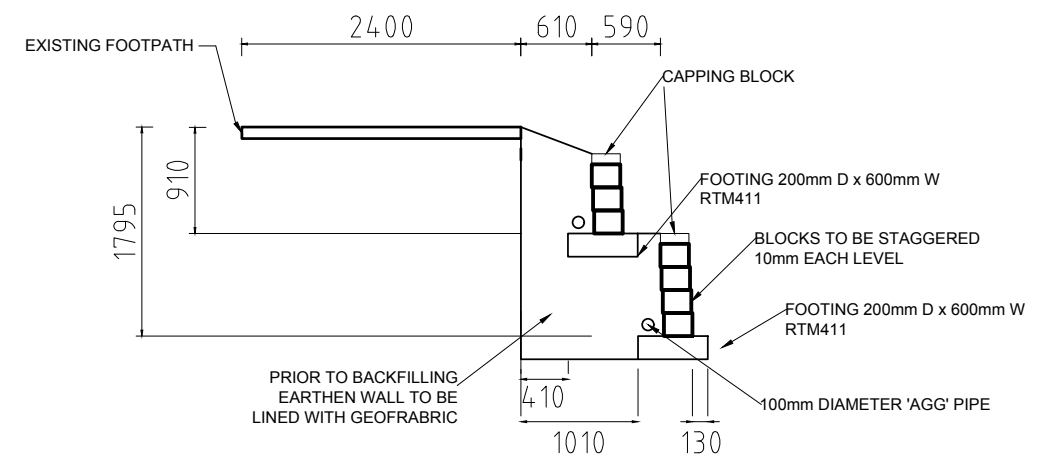

**CBD-UPGRADE-STAGE2
CENTRAL-STORES-CARPARK
CROSS-SECTIONS**

TITLE
CROSS-SECTIONS-SHEET2

CREATION DATE 5NOV2018	DRAFTER CN	APPROVAL FOR ISSUE	
PLOTTED DATE 5NOV18	SCALE 1:65	ENGINEERING MANAGER	MANAGER
DRAWN TO AS1100 BY CAD DO NOT AMEND MANUALLY FIGURED DIMENSIONS TO BE TAKEN IN PREFERENCE TO SCALE READINGS. VERIFY ALL DIMENSIONS ON SITE		SHEET SIZE A3	DRAWING No. CBDP003
		REVISION	1

CHAINAGE 17.300

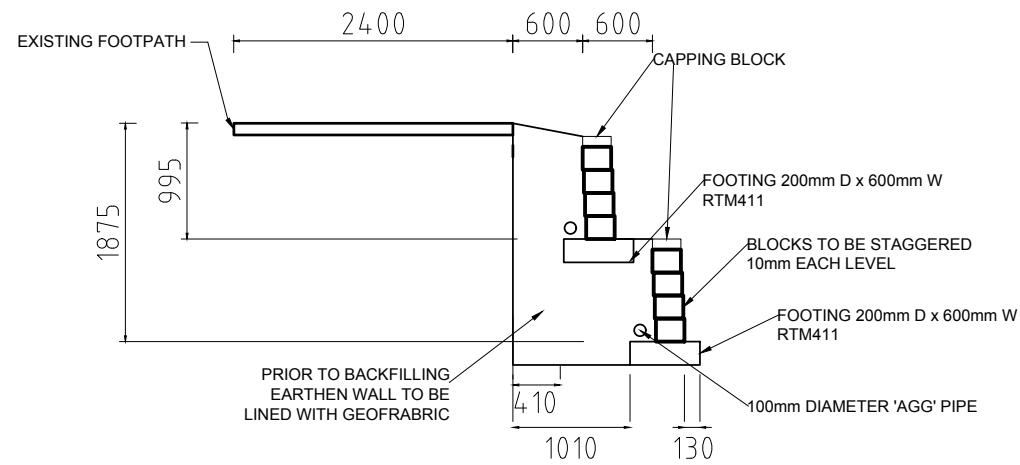

CHAINAGE 19.500

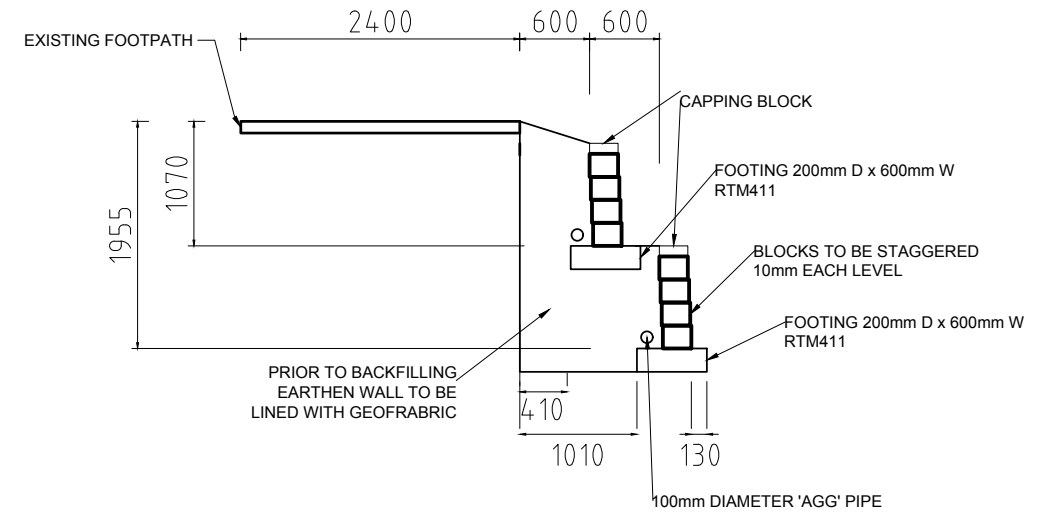

CHAINAGE 24.900

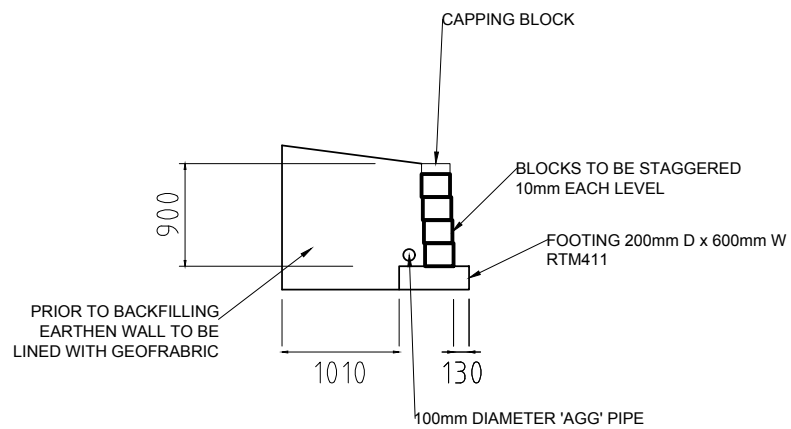

CHAINAGE 27.300

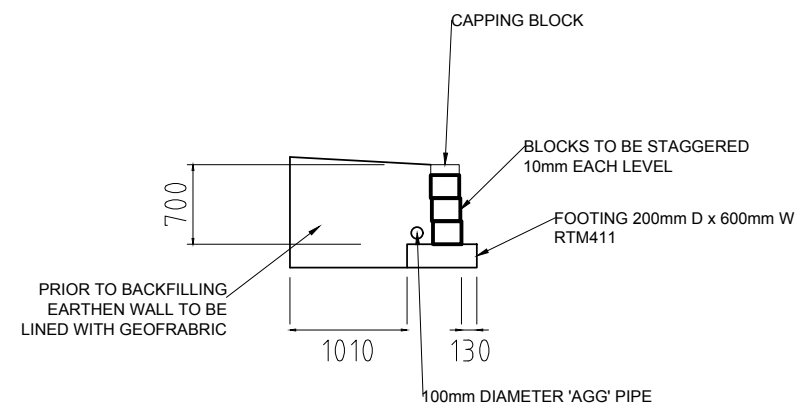

CBD-UPGRADE-STAGE2 CENTRAL-STORES-CARPARK CROSS-SECTIONS

TITLE CROSS-SECTIONS-SHEET3

CREATION DATE 5NOV18	DRAFTER CN	APPROVAL FOR ISSUE	
5NOV18	SCALE 1:65	ENGINEERING MANAGER	MANAGER
DRAWN TO AS1100 BY CAD DO NOT AMEND MANUALLY FIGURED DIMENSIONS TO BE TAKEN IN PREFERENCE TO SCALE READINGS VERIFY ALL DIMENSIONS ON SITE		SHEET SIZE A3	DRAWING No. CBDCP004
		REVISION	1

CHAINAGE 31.500

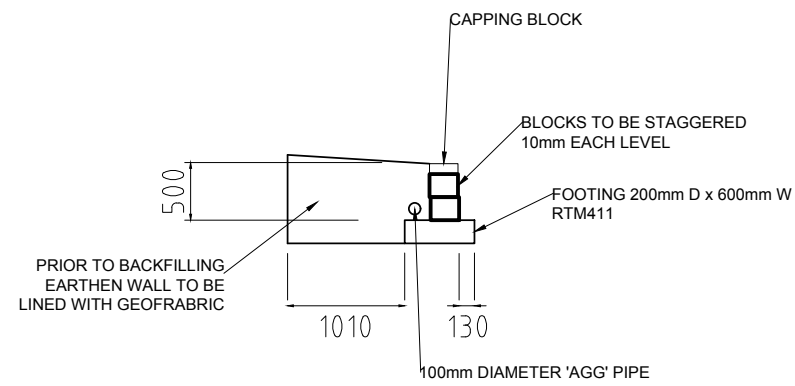

CHAINAGE 34.200

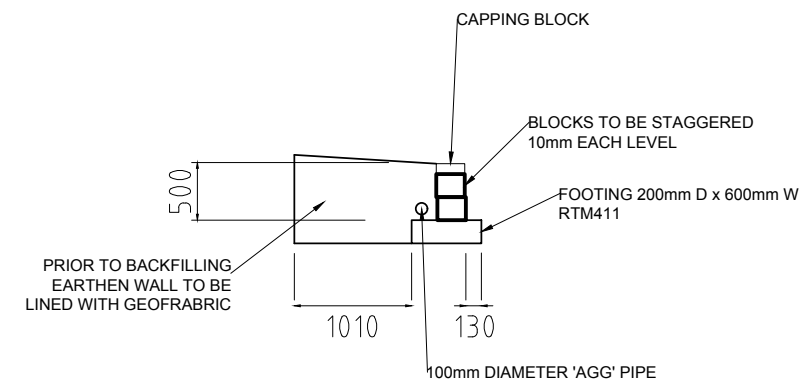

CHAINAGE 36.700

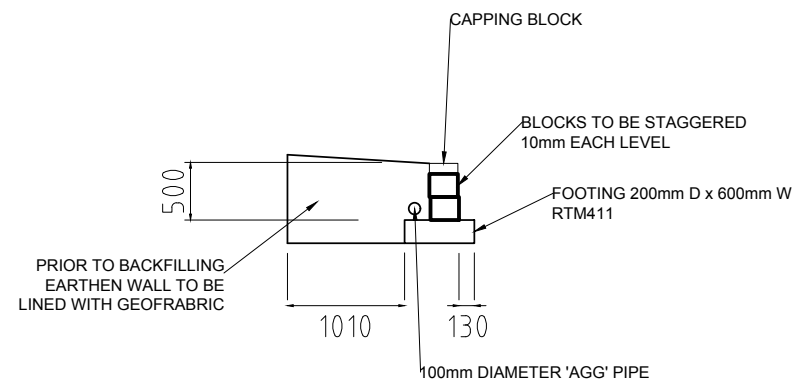

**CBD-UPGRADE-STAGE2
CENTRAL-STORES-CARPARK
CROSS-SECTIONS**

TITLE **CROSS-SECTIONS-SHEET4**

CREATION DATE 5NOV18	DRAFTER CN	APPROVAL FOR ISSUE	
PLOTTED DATE 5NOV18	SCALE 1:65	ENGINEERING MANAGER	MANAGER
DRAWN TO AS1100 BY CAD DO NOT AMEND MANUALLY FIGURED DIMENSIONS TO BE TAKEN IN PREFERENCE TO SCALE READINGS. VERIFY ALL DIMENSIONS ON SITE		SHEET SIZE A3	DRAWING No. CBDPC005
		REVISION	1